

# THICKNESS GAUGES

Dial indicator is used by fitted to Jig etc., while thickness gauge is held simply with our hand. After inserting workpiece between the measuring contacts, releasing the lever will cause the spindle to contact the workpiece and give an accurate size reading. Contact point moves to upward when lifting lever is pressed down, and Contact point returns to "zero" when it is released. As operation is easy, it can measure for a short period compared with micrometer. There are 2 kinds of Dial ,0.01mm, 0.001mm for both of analog and digital. The stroke depends on size of workpiece and a model is available to measure maximum thickness up to 50mm . This can be used for various thickness measurement such as paper, hair, rubber plate, Metal Tube, small molded components.

## Dial Thickness Gauge

- Suitable for measuring thickness and diameter of metal, lens, rubber, plastic, paper, felt, hair, pearl etc., in actual dimension.
- Ceramic contact point and anvil feature high flatness, parallelism, excellent durability and are superior for anti-abrasion and rust.
- Various type ceramic contact point are also available.



**SM-112**  
Graduation 0.01mm  
Measuring Range 10mm

SM-112P (direct reading graduation)



1.17mm reading example



**SM-528**  
Graduation 0.01mm  
Measuring Range 20mm



LS type



LW type



3A type



FE type  
φ10 Flat (steel)



**SM-112AT**  
Contact point and Anvil have special coating for free from adherence.  
Suitable for measurement of adhesive tapes etc.

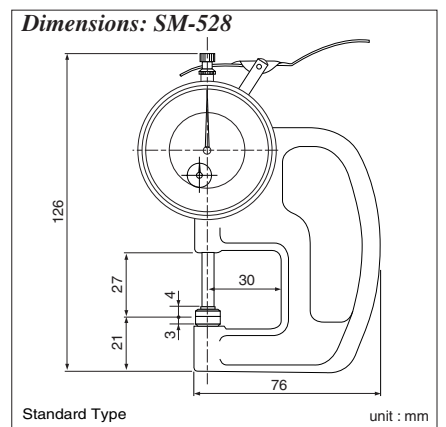
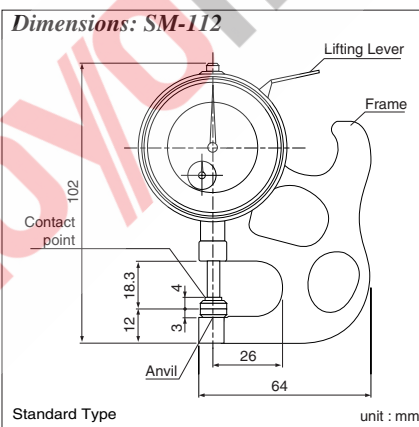

### Specifications

#### SM-112 SERIES

Model	Graduation (mm)	Measuring Range (mm)	Accuracy (μm)	Parallelism (μm)	Dial Reading	Measuring Force (N)	Contact point form (mm)	Anvil form (mm)	Weight (g)
SM-112	0.01	10	15	5	0-50-100	2.5 or less	φ 10 Flat	φ 10 Flat	145
SM-112LS	0.01	10	15	—	0-50-100	2.5 or less	φ 3.2 Ball	φ 10 Flat	145
SM-112LW	0.01	10	15	—	0-50-100	2.5 or less	φ 3.2 Ball	φ 3.2 Ball	145
SM-112-3A	0.01	10	15	5	0-50-100	2.5 or less	φ 5 Flat	φ 5 Flat	145
SM-112-80g	0.01	10	15	5	0-50-100	Stop Point Measuring Forced 0.8±0.05	φ 10 Flat	φ 10 Flat	145
SM-112P	0.01	10	15	5	0-0.5-1	2.5 or less	φ 10 Flat	φ 10 Flat	145
SM-112FE	0.01	10	15	5	0-50-100	2.5 or less	φ 10 Flat	φ 10 Flat	145
SM-112AT	0.01	10	15	8	0-50-100	2.5 or less	φ 10 Flat	φ 10 Flat	145

#### SM-528 SERIES

SM-528	0.01	20	20	5	0-50-100	3.5 or less	φ 10 Flat	φ 10 Flat	200
SM-528LS	0.01	20	20	—	0-50-100	3.5 or less	φ 3.2 Ball	φ 10 Flat	200
SM-528LW	0.01	20	20	—	0-50-100	3.5 or less	φ 3.2 Ball	φ 3.2 Ball	200
SM-528-3A	0.01	20	20	5	0-50-100	3.5 or less	φ 5 Flat	φ 5 Flat	200
SM-528-80g	0.01	20	20	5	0-50-100	Stop Point Measuring Forced 0.8±0.05	φ 10 Flat	φ 10 Flat	200
SM-528FE	0.01	20	20	5	0-50-100	3.5 or less	φ 10 Flat	φ 10 Flat	200