

## SELF POWERED

# GR2 SERIES

- Lithium battery installed inside.  
Battery life 7 years(replaceable)
- Front Panel Protection IP54
- In Conformance to CE(EMC)
- RoHS compliant
- In Conformance to UL



- 7 digits LCD display with 8mm height
- Panel Cut-out 45.0 x 22.2mm

### MODELS

GR2 —    0

#### Type

- C: Totalizer
- H: Hourmeter
- M: Minutemeter
- S: Secondmeter

#### Wiring

0: Terminal screw

#### Input

- 0: Dry contact / Open collector / Voltage (NPN transistor) input
- 1: Wide range voltage input

#### Reset

- 0: Remote
- 1: Remote & Front

### SPECIFICATIONS

Type	GR2-C : Totalizer	GR2-H : Hourmeter	GR2-M : Minutemeter	GR2-S : Secondmeter
Display	7segment LCD 7digits 8mm height			
No. of digit	0 - 9999999	0.0 - 999999.9		
Spec of input	Max.count speed GR2-C□00 30Hz GR2-C□10 20Hz	Resolution 1count per 1/10 hour	Resolution 1count per 1/10 minute	Resolution 1count per 1/10 second

### MECHANICAL / ENVIRONMENTAL SPECIFICATIONS

Ambient Temp. : Operating	-10 - +55°C (Non-freezing)
Ambient Temp. : Storage	-20 - +65°C (Non-freezing)
Ambient Humid. : Operating	25 - 85%RH (Non-condensing)
Vibration / Shock resistance	Operation : Single amplitude 0.35mm Frequency 10 - 55Hz X.Y.Z. Axis 100mm/s <sup>2</sup> Storage : Single amplitude 0.75mm Frequency 10 - 55Hz X.Y.Z. Axis 300mm/s <sup>2</sup>
Protection of front panel	IP54
Weight	50g (Battery included)
Wiring	M3 Terminal screw

## ELECTRICAL SPECIFICATIONS

<b>Input</b>	Dry Contact / Open collector / Voltage (NPN transistor) Wide range voltage	L:<0.8V H:2 - 30V L:DC/AC 0 - 5V H:DC/AC 20 - 250V	Sink current 8 # A Input impedance:300kΩ
<b>Reset</b>	Front Reset Remote Reset Dry Contact / Open collector / Voltage (NPN transistor) Wide range voltage	L:<0.8V H:2 - 30V L:DC/AC 0 - 5V H:DC/AC 20 - 250V	Sink current 8 # A Input impedance:300kΩ
<b>Reset pulse width</b>	6ms MIN.		
<b>Power source</b>	3.6V 1/2AA Lithium Battery (replaceable), 7 years min. with continuous input at 25°C *The battery life is not a guaranteed value.		
<b>Noise immunity</b>	Electrostatic Discharge	IEC-61000-4-2	8kV
	Radiated Electromagnetic Field	IEC-61000-4-3	10V/m
	EFT/B.I/O Leads	IEC-61000-4-4	1.0kV
<b>EMC standard</b>	EMI : EN50081-2 EMS: EN50082-2		

## DIMENSIONS

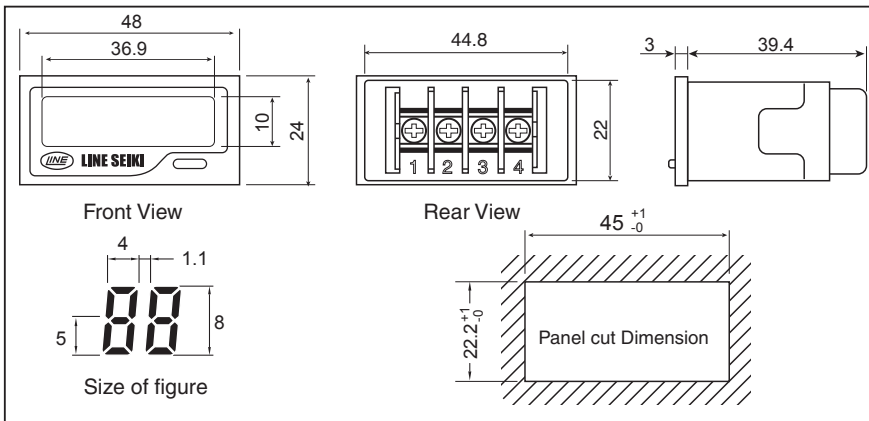

## MOUNTING

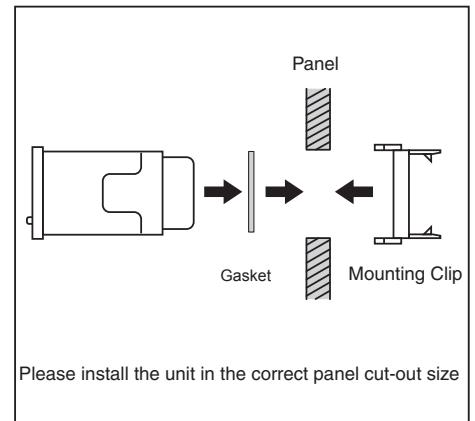

## WIRING

<GR2-□□00>

- Dry Contact / Open collector / Voltage (NPN transistor) Input type

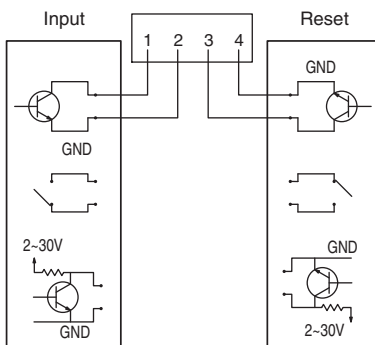

<GR2-□□10>

- Wide range voltage input type

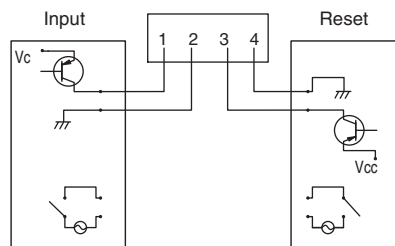

Theory on GR Series Counter

<GR2-□□00>

Dry Contact / Open collector / Voltage (NPN transistor) Input

Input terminal No.1 : Count at Hi → Lo

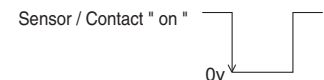

<GR2-□□10>

Wide range voltage input

Input terminal No.1 : Count at Lo → Hi

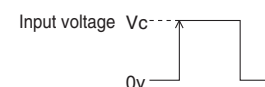

\* Specifications Subject to Change Without Prior Notice  
All Rights Reserved, Copyright © 2014 Line Seiki Co., Ltd.



**LINE SEIKI CO.,LTD.**

Address : 37-7, Chuo-Cho, 2-Chome, Meguro-ku  
Tokyo 152-0001 JAPAN

Contacts : Tel: +81-3-3716-5151 Fax: +81-3-3710-4552

E-mail: [webtrade@line.co.jp](mailto:webtrade@line.co.jp)

URL : <http://www.lineseiki.com>